

REVISION HISTORY				
ZONE	REV	DESCRIPTION	DATE	DESIGNER
	1	Updated weight quadra rake	11-9-2017	cvdknaap

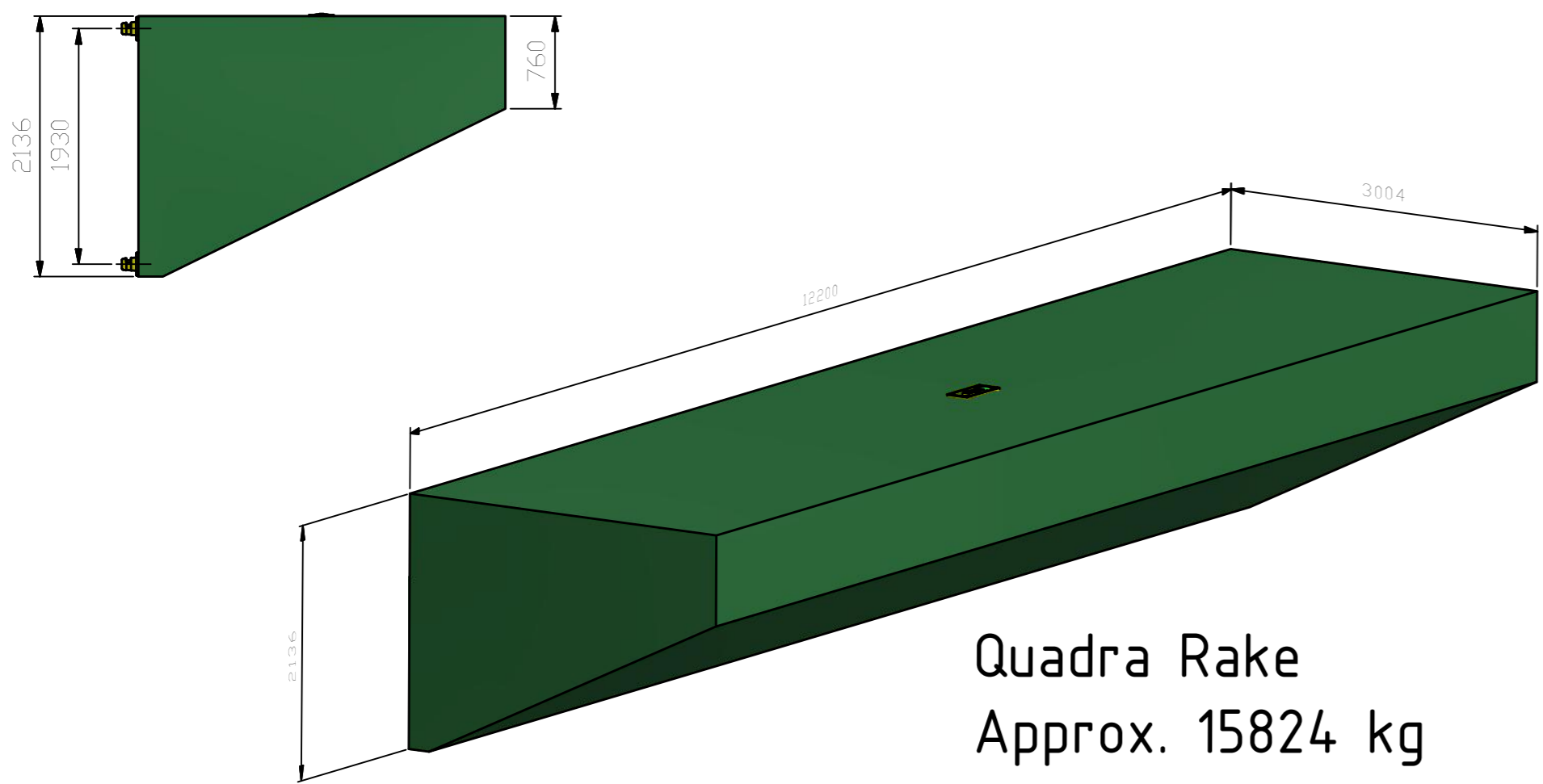

Quadra Rake
Approx. 15824 kg

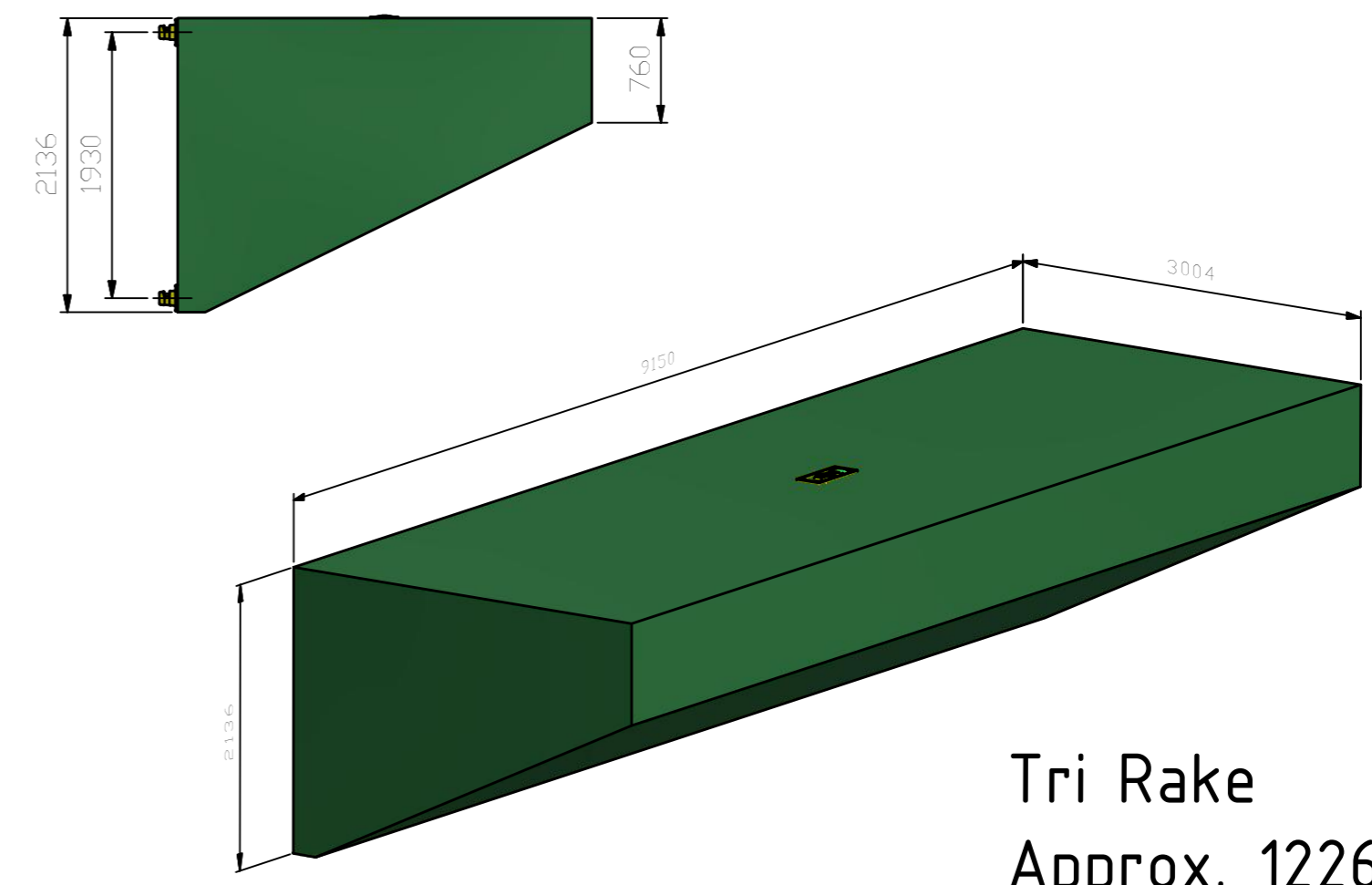

Tri Rake
Approx. 12268 kg

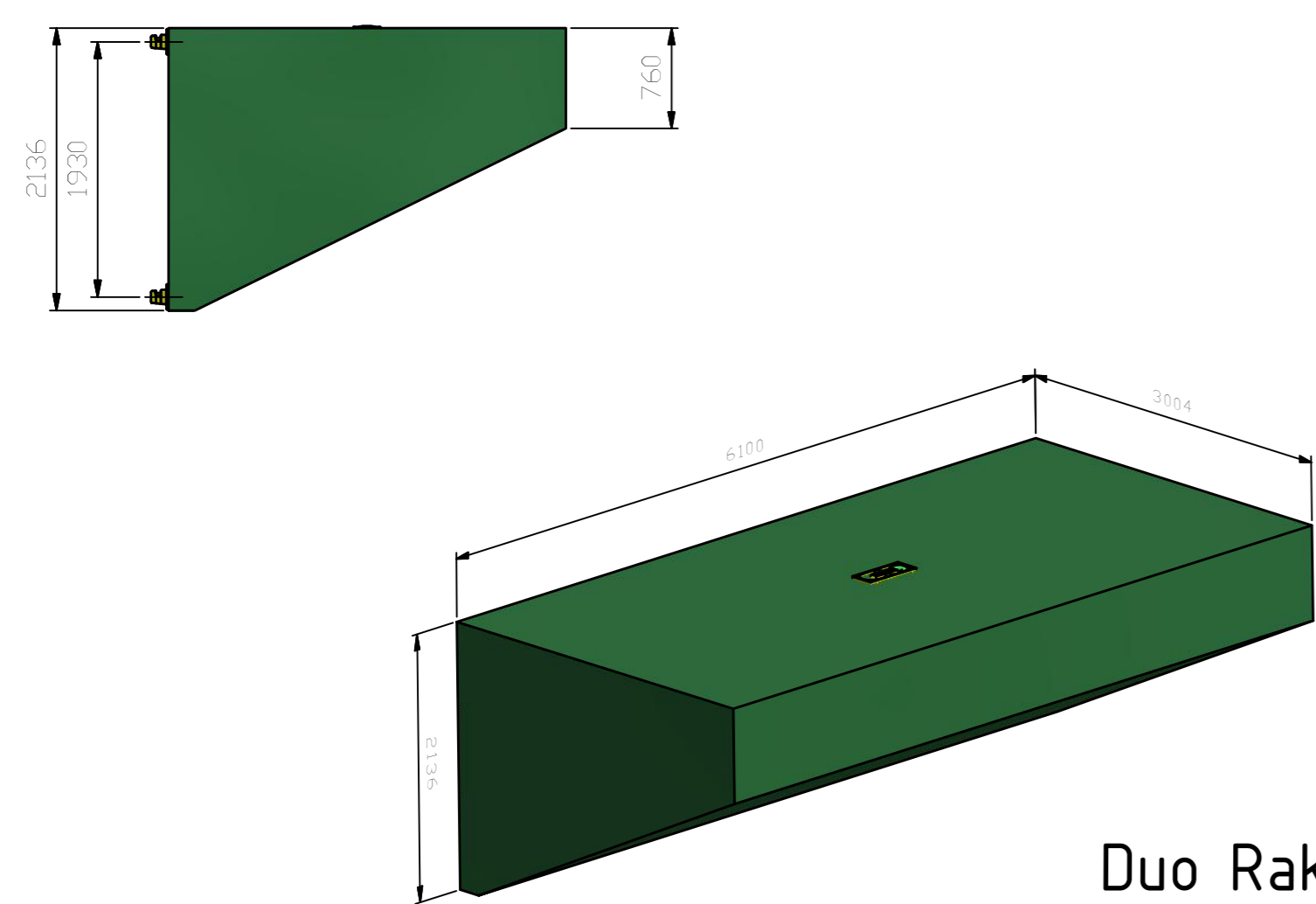

Duo Rake
Approx. 8342 kg

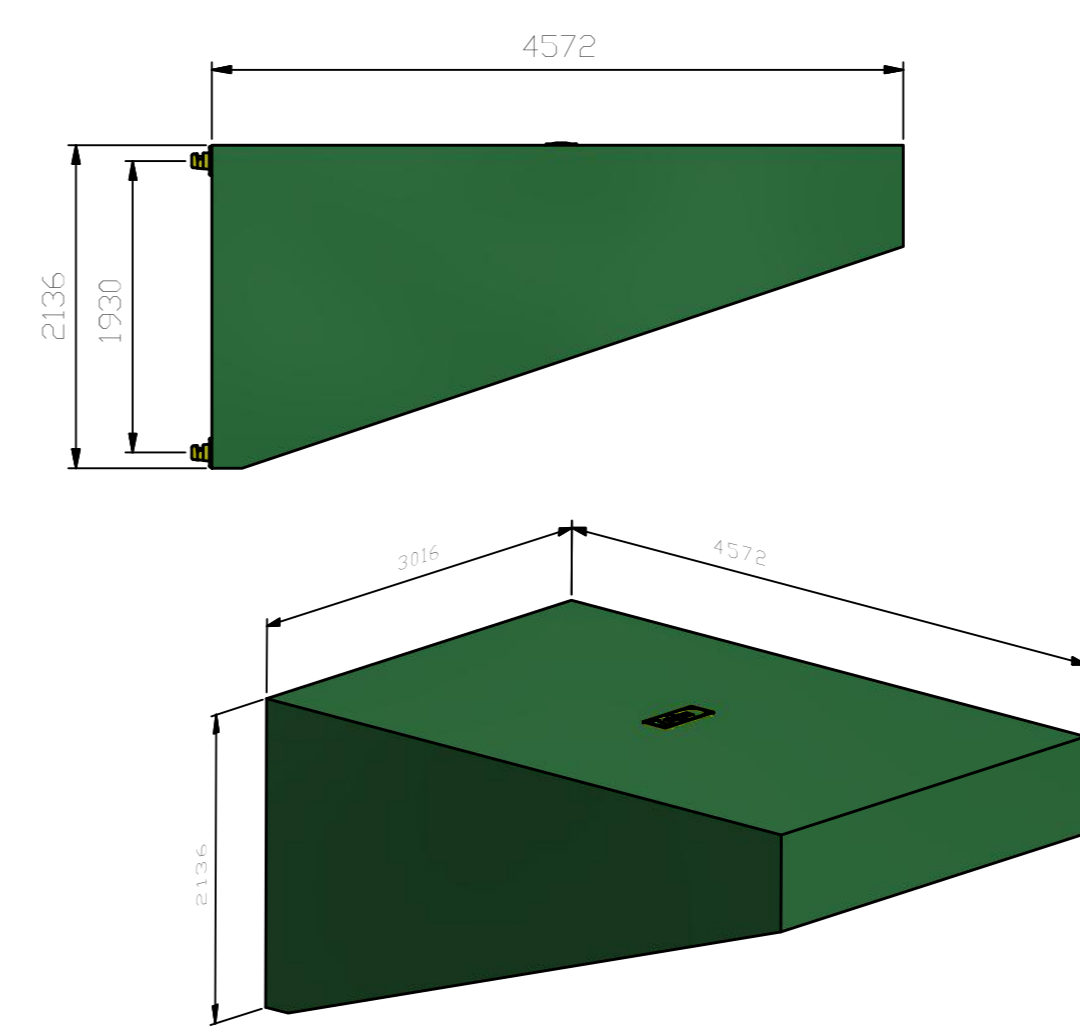

End Rake (Uni Rake)
Approx. 5080 kg

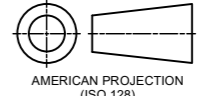
Concerns :		Unit - Name : Summary of C-7 Rakes	
		Scale :	Drawn by : cvdknaap Date : 8-4-2013
			Checked by : Date :
COMBIFLOAT SYSTEMS B.V. Rivium Quadrant 75-8, 2909LC, Capelle a/d IJssel, +31(0)104370811 - www.combifloat.com		NOTATION ACC Dimension ISO 446 Geometrics ISO 1101 Roughness ISO 1302	TOLERANCES ACC Welding ISO 13920-AE Cutting DIN 2310-IA,IC,IG,JK Machining ISO 2768-mK Plate Thickness EN 10029-AN Castings ISO 8062-CT11
		Drawing nr. : S897.12	